

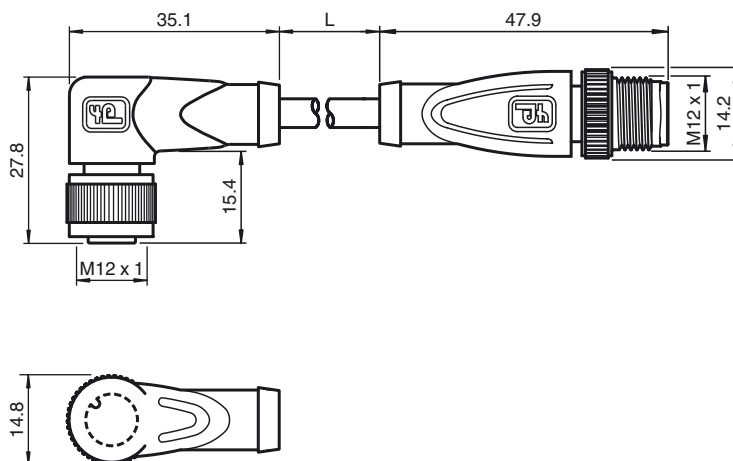

Dimensions



Model Number

V15-W-3M-PUR-ABG-V15-G
 Connecting cable, M12 to M12, 5-pin, shielded, PUR cable

Features

- Knurled nut suitable for tool assembly
- Immunity to vibration, with mechanical latching
- Shield attached to coupling nut
- Gold plated contacts
- Halogen-free

Technical data

General specifications

| | |
|----------------|------------|
| Number of pins | 5 + shield |
|----------------|------------|

Electrical specifications

| | | |
|-------------------|-------|-----------------|
| Operating voltage | U_B | max. 60 V AC/DC |
| Operating current | I_B | max. 4 A |
| Volume resistance | | < 5 m Ω |

Ambient conditions

| | |
|---------------------|--|
| Ambient temperature | Body: -40 ... 90 °C (-40 ... 194 °F) cable, flexing: -25 ... 80 °C (-13 ... 176 °F) cable, fixed: -40 ... 80 °C (-40 ... 176 °F) |
| Pollution Degree | 3 |

Mechanical specifications

| | |
|------------------------|--|
| Contact elements | spring-loaded contact socket |
| Pin diameter | 1 mm |
| Degree of protection | IP67 |
| Material | |
| Contacts | CuSn / Au |
| Contact surface | Au |
| Body | TPU, black |
| Cable | PUR |
| Slotted nut | Diecast zinc |
| Sleeve connector | Diecast zinc |
| Core insulation | PP |
| Cable | extra-fine wire, flexible |
| Sheath diameter | \varnothing 4.8 mm |
| Bending radius | > 10 x cable diameter, moving > 5 x cable diameter, fixed |
| Color | grey |
| Cores | 5 x 0.34 mm ² |
| Conductor construction | 42 x 0.1 mm \varnothing |
| Shield | grid covering 85 % |
| Length | L 3 m |
| Flammability | |
| Contact carrier | HB |
| Housing | V-2 |

Compliance with standards and directives

| | |
|----------------------------|----------------------|
| Standard conformity | |
| Degree of protection | EN 60529:2000 |
| Standards | IEC 61076-2-101:2008 |
| Flammability | Grip: UL 94 |

Electrical connection

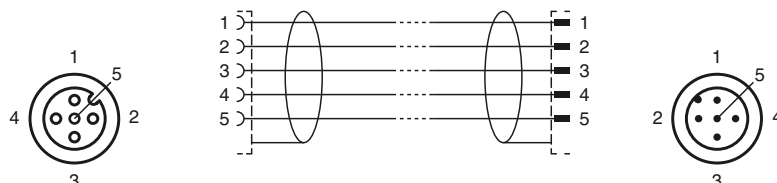

Release date: 2015-08-11 11:20 Date of issue: 2015-08-11 240788-0004_eng.xml